



Web Tension Design

Chapter I - Problems Solved by Web Tension Measurement 2

Improved Product Quality 2

Faster Setup 2

Higher Productivity 2

Chapter II - Web Tension Measurement 2

Do Web Tension Transducers Differ 2

Where Do They Mount? 3

How Do I Know the Measurement is Exact? 3

Chapter III - Mechanical Application Information 4

Where Do I Install the System? 4

Do Wrap Angles Really Matter? 5

What About Roll Imbalance? 5

Is Speed an Installation Factor? 6

Chapter IV - Selecting System Instrumentation 7

Are There Environmental Concerns? 7

Should Each Transducer be Evaluated? 7

How Fast Should The Instrument Respond? 8

How Many Instruments Does a System Require? 8

How Are Multiple Instrument Systems Controlled? 8

Chapter V - Transducer Sizing 9

How About Roll Weights? 10

Chapter VI - Intrinsic Safety 11

What is the Basis of Intrinsic Safety? 11

What Do the Different Classifications Mean? 11

Will I Need A Special Enclosure? 12

Do I Need Intrinsic Safety Barriers? 12

How Does Intrinsic Safety Work? 12

How Can I Tell If My Equipment Is Safe To Use? 12

Chapter VII - Glossary 14

Web Tension Design

Chapter I - Problems Solved by Web Tension Measurement

Processing of a web at optimum web tension is a goal that must be achieved to produce high quality material in many web processing industries (paper, film, foil, rubber, non-wovens, metal, plastic, linoleum) and in many web converting processes (coating, laminating, printing, embossing, slitting). Proper tension during winding of any continuous web product is critical to roll quality. Optimum control of tension during unwinding assures that the web is fed smoothly into the process and prevents web damage.

Installation of a Vishay BLH Electronics Web Tension Measurement System provides the following benefits to your continuous web process:

- **Improved Product Quality**

Accurate and consistent web tension eliminates overstretching or understretching of the web, improves registration, eliminates wrinkles, and improves dimensional control. Dancer rolls, which may cause quality problems in fragile webs, in many cases can be eliminated.

- **Faster Setup**

Adirect indication of web tension enables an operator to reproduce the proper tension of any web easily and consistently. This allows different material types with varying web widths to run on a single machine.

- **Higher Productivity**

- Optimum web tension control allows higher running speed for increased production.
- Analysis at critical points throughout the machine of how web tension changes as other process variables change, leads to improved machine control using in-process web tension as one variable. The result is improved quality consistency, increased production rates, and more efficient machine operation.
- With normally consistent web tension and with breakage alarms (set to go off before the web reaches a breaking point), web breaks are virtually eliminated, thus reducing material waste and lost production time.
- Improved web tension control is achieved via manual control based on an accurate indication of web tension, or via automatic control based on a tension signal feedback to a drive, brake, or clutch control.

Chapter II - Web Tension Measurement

Tension Measurement and Control systems consist of one or two Web Tension Measurement Transducers/Modules, along with associated junction box(es) and instrumentation. The heart of a successful T-MAC system is the transducer/module (a tension module includes the transducer and mounting hardware). Vishay BLH manufactures a complete line of web tension transducers to cover applications ranging from milligrams to thousands of pounds.

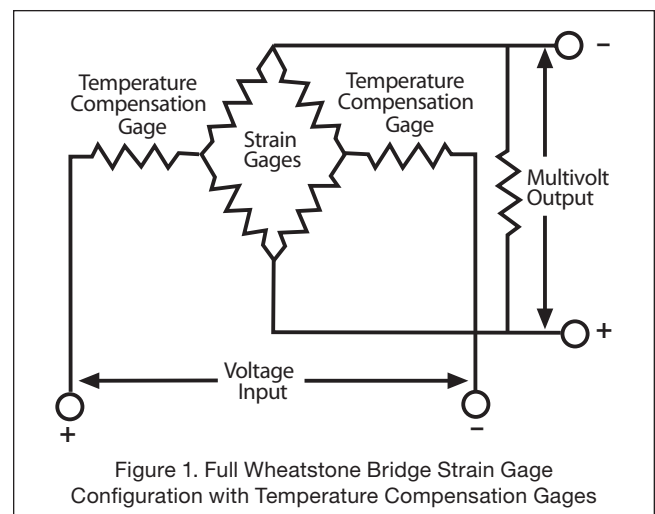

Do Web Tension Transducers Differ?

Most web tension transducer/module manufacturers rely on semi-conductor strain gages which, unfortunately, have many limitations. In high tension applications they can be severely affected by temperature, steam, corrosive gases, chemicals and many other common contaminants, and in low tension applications they offer very limited

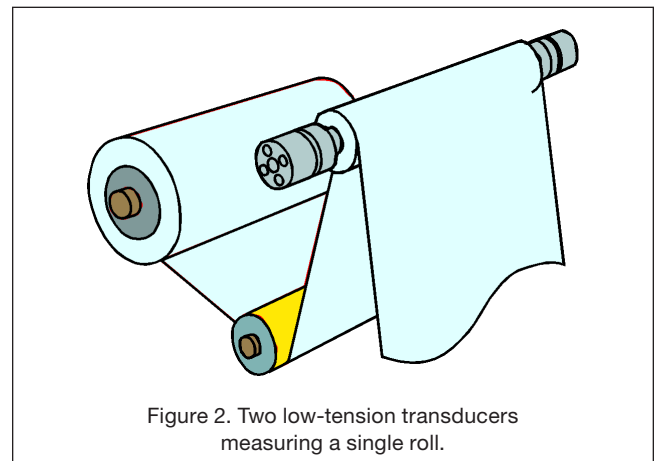

Web Tension Design

range ability. BLH transducers incorporate SR-4 Foil strain gages connected into a full Wheatstone bridge that is temperature compensated and dead weight calibrated to deliver accuracy, high-performance and reliability. They feature superior sealing to stand up to the hostile environments of high tension applications.

In low tension applications, the full Wheatstone bridge design provides rangeability that is often 10 times greater than transducers built with semiconductor strain gages. Also, they require no recalibration.

Where Do They Mount?

Lower tension transducers typically install at the end of idler rolls (one transducer on each end) or in place of a cantilevered idler roller (single sided machines). Using two transducers, one on each end of the roll, provides measurement statistics for left, right, and total tension.

Ultra low tension transducers attach directly to in-line pulleys to measure single strands or filaments.

High tension modules usually mount directly beneath a standard pillow block bearing. The bearing is mounted on a load plate that is, in turn, bolted to the tension module. The HTA design places the tension transducer exactly at the center line of the bearing. This arrangement cancels out bearing friction forces and maintains accurate tension measurement during critical periods of start-up and shutdown.

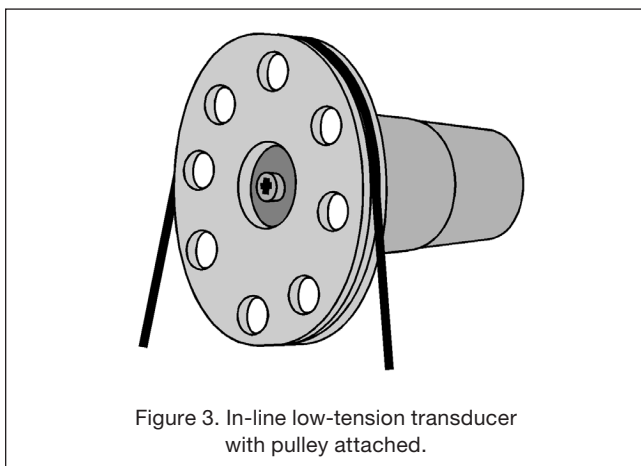

Figure 3. In-line low-tension transducer with pulley attached.

Optimal measurements are obtained by mounting transducers under both roll-end pillow block bearings (see illustration below). This arrangement provides measurement statistics for left, right, total, and differential tension. When combined with precision instrumentation, dual transducer installations pinpoint exact web center,

detect web shifts, and alert operating personnel to potential failures before they occur.

How do I Know the Measurement is Exact?

The goal of any installation is to measure precise web tension force while rejecting or eliminating all other signal components such as machine vibration, roll weight, etc. Although these factors can be dampened or calibrated

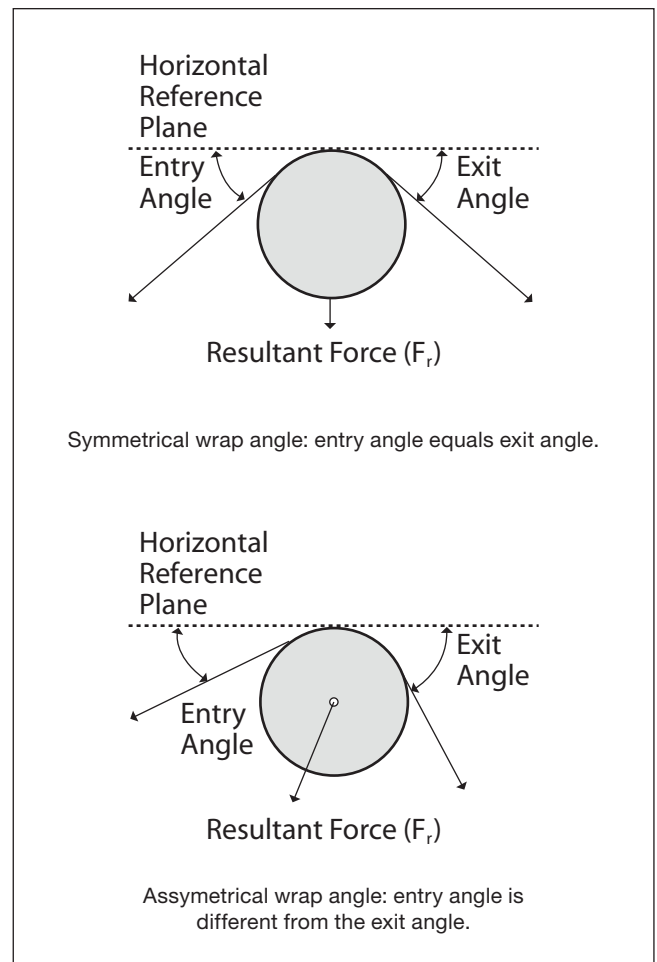

out™ with good instrumentation, determining the maximum tension force, F_r , also depends upon web wrap angles.

Some manufacturers offer only horizontal or vertical measurement transducers. For systems with asymmetrical wrap angles, some portion of the resultant tension signal will always be lost.

To achieve precision accuracy, all BLH manufactured low tension transducers are cylindrical in design. During system

Web Tension Design

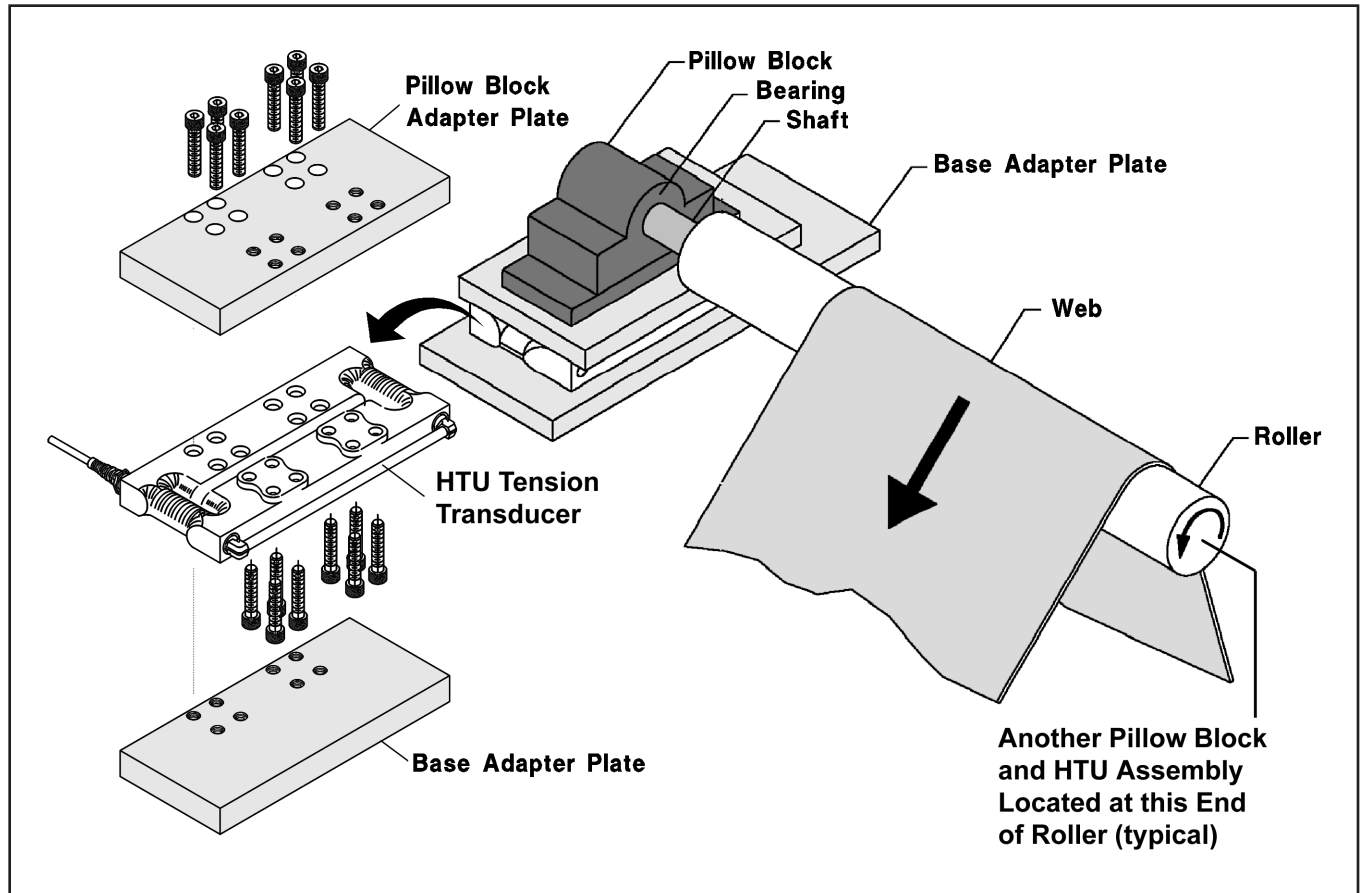

start-up, engineering/operating personnel need only rotate the transducer while observing the system instrument or readout device. When optimal readings are observed, just tighten the transducer bolt. In this way, the full resultant force signal is captured at the precise Fr angle.

Similarly, Vishay BLH high tension modules measure both horizontal and vertical force components. Four sets of strain gages in each transducer measure both force directions simultaneously. An Expert Series™ instrument then calculates the exact resultant force angle and continues to do so even during dynamic system processing.

Chapter III - Mechanical Application Information

When preparing to introduce a T-MAC system into an installation, the following points should be considered:

- Tension zone(s) of interest
- Ambient temperature
- Constant wrap angles

- Idler roll
- Operating speed

Where Do I Install the System?

In some cases there is no choice in mounting location since the measurement of interest can only be made at one specific location. In other cases there will be a number of locations suitable for the measurement. For example, to increase the useful lifetime of a felt on a paper machine by controlling the tension applied to it, there may be a dozen or more rolls where the felt tension could be measured. Consideration of the following factors, listed in order of importance, will help to optimize the system's overall performance.

1. Enough physical space must be available for transducer mounting.
2. Constant wrap angles... From the calculations which appear in subsequent sections of this manual it can be seen that the wrap angle has a profound effect upon the forces being measured. Varying wrap angles will

Web Tension Design

therefore vary the output from the tension module(s) even though tension may be constant.

3. Ambient temperature at the mounting location should be within the compensated range of the transducers and must be within the safe range of the transducers. Vishay BLH module compensation typically ranges from 15°F to 150°F (visit www.webtension.com for specifications).
4. Light rolls will often yield better results than heavy rolls since the tension module capacity can be minimized. A lower module capacity results in a higher signal level and better resolution.
5. Measurements taken on an idler roll are more accurate than measurements taken on a driven roll because the upstream and down-stream tensions on the driven roll will not be equal. The measurement made on a driven roll will be roughly the average of the two tensions.

NOTE: Because of the high accuracy of Vishay BLH web tension modules, there are no limitations on wrap angles or roll weights.

Do Wrap Angles Really Matter?

Usually, entry and exit deflection angles are constant and defined by fixed deflection points. However, in some cases the location of the tension module(s) is such that the angles can vary.

Wrap angles in some installations simply are not constant. For ex-ample, in the wire section of a paper machine, one or

more rolls are adjustable to compensate for the elongation of the wire over its lifetime. Depending upon the geometry of the machine, this elongation adjustment could change the wrap angle on the measured roll.

The resultant force would not be directly proportional to tension. If the error introduced cannot be accepted, a deflector roll must be added to completely define the geometry of the measured roll.

The following are some examples of methods used to define the geometry immediately adjacent to the measured roll through the use of deflector rolls. Three common configurations are one roll, two rolls, and three rolls.

1. One roll configurations apply when the wrap angle geometry is defined by other fixed rolls in the process line.
2. A single deflector roll, or two roll configuration, is used when the geometry is defined on one side of the measured roll, but undefined on the other side.
3. Three roll configurations are recommended when the wrap angle geometry is undefined on both sides of the measured roll.

Note: If a Vishay BLH HTU system is installed, resultant force angles are automatically calculated along with system tension, providing complete run-time analysis.

What About Roll Imbalance?

Tension measurement system characteristics require that the roll balance fall within close tolerances. Rolls should

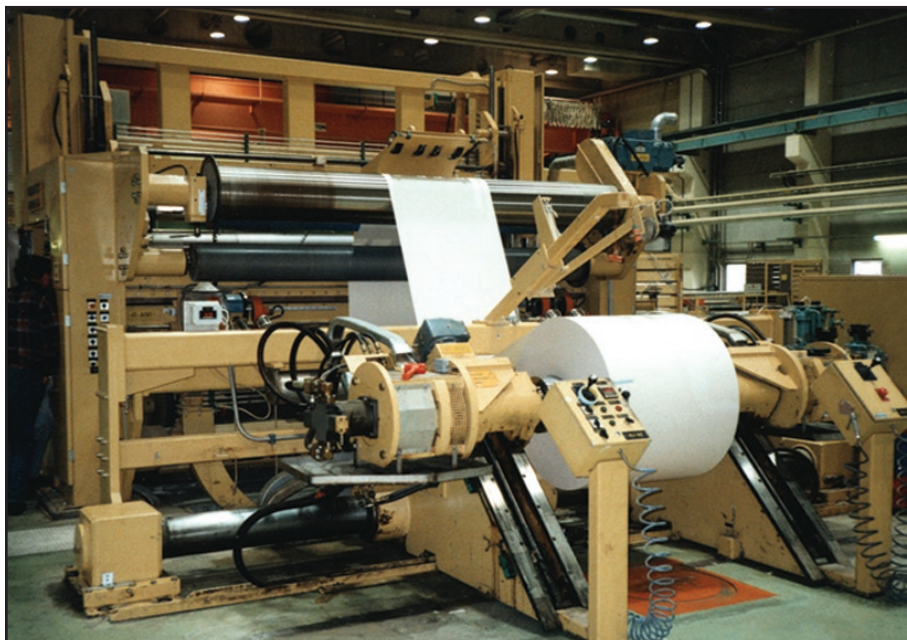

- **Installation Locations:** press sections, coaters, breaker stacks, pick-up felts, bottom felts, vacuum chambers, winders, unwinders, rewinders, slitters, calenders, laminators, conveyor belts.
- **Equipment Types:** paper machines, convert-ing equipment, roofing machines, printing presses, rubber and metal strip forming machines, mining conveyor belts, textile machinery.
- **Products Produced:** paper, films, foil, asphalt shingles, plastic rolls/sheets, fiber optic cable, filaments, threads, tapes, tags, labels.

Web Tension Design

be dynamically balanced at the maximum roll speed so that the effect of imbalance forces on tension measurement can be minimized. Some amount of imbalance force can be accepted. However, if the sum of the imbalance force and the total force carried by the transducer exceeds the linear range of the transducer or signal conditioners, a distorted signal will result which will produce an erroneous output signal. The imbalance force, F_{imb} , is calculated according to the formula on the next page.

$$F_{imb} = (e) (m) (2\pi f)^2$$

Where:

- F_{imb} = imbalance force (lb)
- e = eccentricity of the imbalance mass (ft)
- m = imbalance mass (lb m)
- f = rotational frequency (Hz)

If the formula data is unknown, the imbalance force can be obtained from the roll manufacturer or balancer.

Is Speed an Installation Factor?

The natural frequency of the measured roll assembly depends approximately upon the transducer spring constant and the roll mass if the roll and the transducer support structure are sufficiently stiff. Transducer spring constant values should be available from the manufacturer. The natural frequency corresponds to a critical speed n_{res} , according to the formula:

$$n_{res} = 187.5 \sqrt{k/w}$$

Where:

- n_{res} = critical speed (rpm)
- k = spring constant (lb/in)
- w = 1/2 total weight of roll and bearings, where applicable (lb)

It should be verified that the running speed of the measured roll does not reach the critical speed — or quickly passes through the critical speed — to assure that large vibrations do not damage the transducers.

Rolls should be dynamically balanced at the maximum roll speed so that the effect of imbalance forces on tension measurement can be minimized.

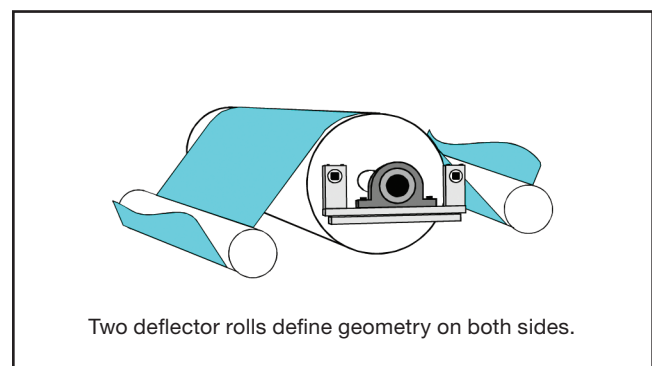
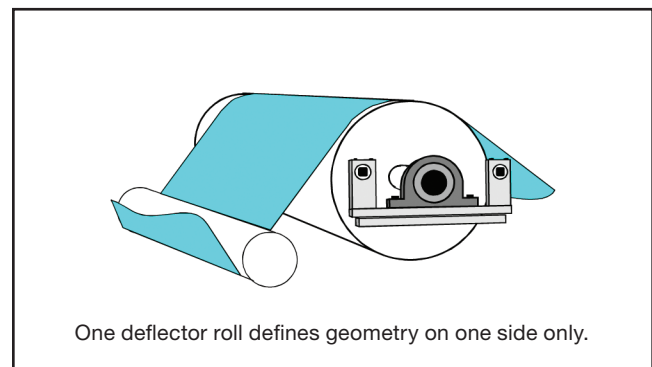
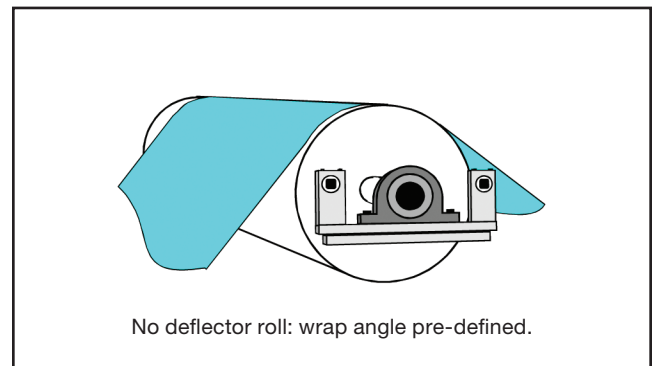
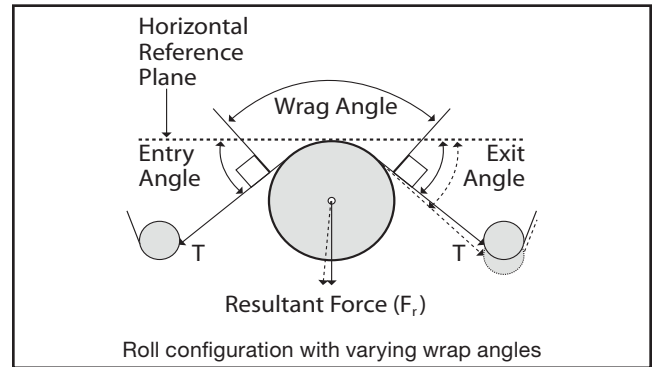

Web Tension Design

Chapter IV - Selecting System Instrumentation

Since tension modules utilize strain gage force transducers, T-MAC system instrumentation must perform basic functions such as excitation voltage supply and signal amplification. Also, with most applications requiring documentation or plant integration, some form of digital communication interface becomes necessary.

In multi-transducer installations, i.e. one transducer at each roll end, individual transducer signals must be summed to provide a total tension value.

In addition to these basic functions, in some cases an analog output signal proportional to total web tension fulfills process requirements. In other cases, additional features are required to ensure flexibility and optimum T-MAC system performance.

Are There Environmental Concerns?

In many cases the answer is YES! Instruments typically install as close as possible to the transducers. This maximizes the signal integrity through manufacturer supplied cables. Since the transducers often are located in harsh, hot, or even hazardous areas, system instrumentation must likewise be protected.

When designing a system, look for instruments housed in NEMA 4/4X enclosures. Although not always necessary, this type of enclosure is desirable for humid, wash down areas and also provides excellent EMI/RFI electrical shielding. Often they will carry FM and CSA approvals as extra insurance.

To determine if an application area is a hazardous location, request a copy of A Guide to SAFE Weighing in Hazardous Locations. This publication defines hazardous environments and the equipment needed for safe operation within these areas. Vishay BLH provides complete systems, including barriers, for all Div. 1, 2 ; Class I, II, III; Group A-G locations.

Should Each Transducer's Performance be Evaluated?

Output data from each transducer is crucial, although, in some systems, transducer signals need only to be summed to produce a total tension value. Instruments used for these applications often contain internal summing circuitry (eliminating the need for external junction boxes) and possibly a low resolution analog output signal for clutch motor control.

More complex systems, those that track process trends, compute web center values, or monitor left and right roll tension values, require precision data evaluation. Instrumentation for these systems should provide individual A/D converters for each system transducer.



Four channel (4 - A/D converters), four display diagnostic controller with 16-bit analog signal control output.



High speed (120 updates/second) bi-polar transducer indicator with 16-bit analog signal control output.



High speed (120 updates/second) din rail mount transducer indicator with 14-bit analog signal control output.

Web tension transmitter measuring left, right, and total tension (single roll with two transducers) integral summing eliminates need for external junction box.

Web Tension Design

These instruments allow operating personnel to monitor web shifts by viewing left, right, and total tension values. Diagnostic algorithms inherent in these units detect system overload/overstress symptoms as machine speeds or process materials change and alert operating personnel. Analog outputs from these systems will typically be very high resolution (16 bit minimum) for precise control of clutch drive motor or breaks.

How Fast Should the Instrument Respond?

High tension system (paper machines, roofing machines, mining conveyors, etc.) analog drive components (break/clutch controls) typically have a response time in the hundreds of milliseconds to seconds, depending upon size and power. For these components, an instrument update rate of 20 conversions per second (50 msec) is more than adequate. This output rate is usually greater than 2X (twice) the speed of larger motor drive components, and therefore, satisfactory (see Table below).

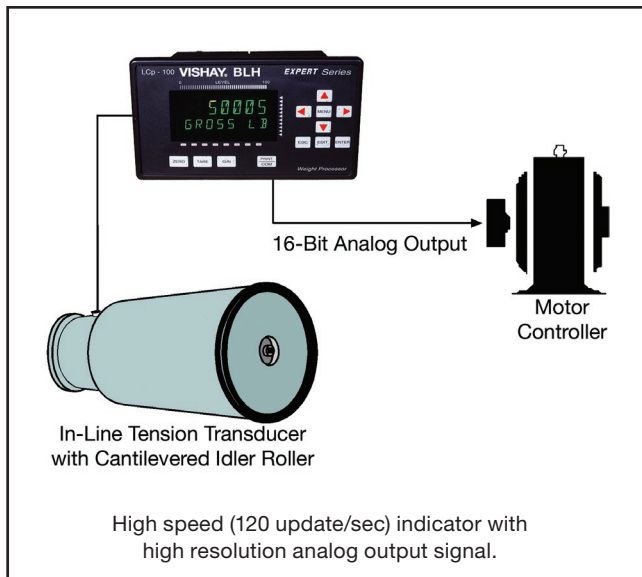

T sec	τ	f_c Hz	S per sec
2	0.6	0.28	0.5
1	0.3	0.55	1
0.5	0.16	1.04	2
0.2	0.06	2.77	5
0.1	0.03	5.55	10
0.05	0.016	10.4	20
0.02	0.006	27.7	50
0.01	0.003	55.5	100

Where:

- T = analog (motor) response time (to 95%)
- τ = the time constant
- f_c = frequency response
- S = instrument update rate

Based upon the formulas:

$$f = \frac{1}{2\pi\tau} \quad S \text{ (approx.)} = 2f_c$$

In lighter (low) tension applications (converting equipment, etc.), where control devices are much smaller, motor response times maybe as fast as 50 or 60 milliseconds. With webs moving much faster in these machines (2000 feet/min. and greater), a 20-per-second instrument update rate may not be acceptable. Some engineers prefer to have the instrument drive signal at least twice the frequency of the motor controller. For these installations, look for instrumentation with an update rate ranging to 120 conversions per second (8 - 10msec). (See Table this page.)

How Many Instruments Does a System Require?

Depending upon the machine size and number of points being measured, a general rule of thumb is one instrument per roll. This is especially true if the roll is being measured by two (left and right) transducers. However, an exception to this rule occurs when instrumentation provides A/D conversion for each transducer. Such an instrument can measure two or more rolls quite economically.

How Are Multiple Instrument Systems Controlled?

Systems with multiple measurement points usually require multiple instruments. Multiple instrument systems should be controlled and coordinated by a supervisory host PLC or DCS system. Vishay BLH instruments offer a choice of Allen-Bradley Remote I/O, Modbus Plus, or Profibus digital interfacing. In most cases, a simple three-wire network ties all instruments to the common host device. Another advantage to using a supervisory host is total system control. Based upon tension measurements from all machine points, the host makes decisions concerning overall machine speed and controls various clutches/breaks accordingly.



Web Tension Design

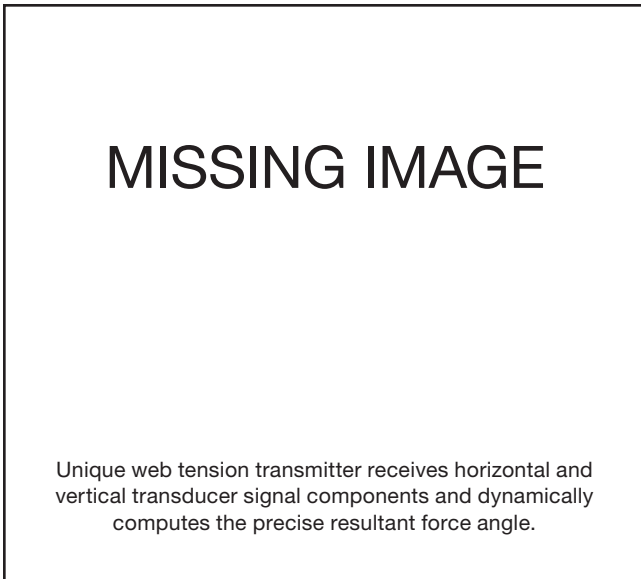
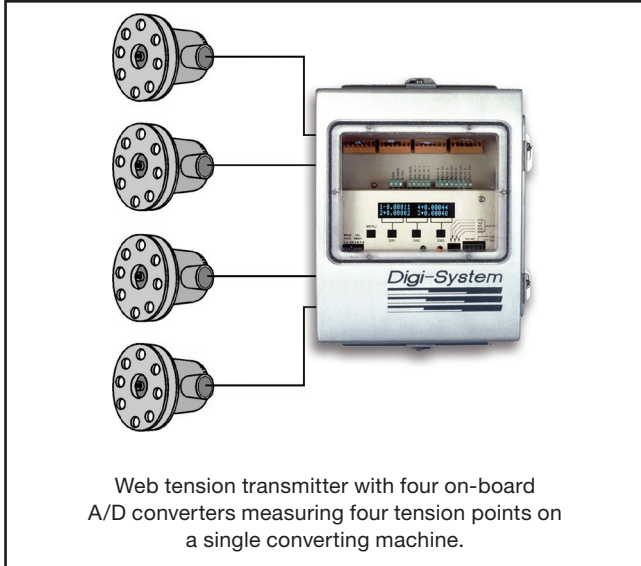

Chapter V - Transducer Sizing

Although correct sizing of a T-MAC System is straightforward, an understanding of basic vector mechanics is required. Consideration must be given to the maximum tension in the web, the weight of the idler roll, bearings, and the web entry and exit angles. The purpose of this section is to provide some insight into this process. If you would like Vishay BLH to determine the proper transducer capacity selection, simply fill in the Web Tension Worksheet Information Sheet supplied with this Application Guide and send or FAX to Vishay BLH Applications Engineering.

The information required for sizing is:

- W: Roll weight (lb)
- L: Web width (in.)
- Tu: Unit web tension (lb/in.)
- T: Total web tension, $L \cdot L \cdot Tu$ (lb)
- α : Web entry angle (degrees)
- β : Web exit angle (degrees)

The following illustration graphically represents the sign convention for the entry angle (α) and exit angle (β). Note that calculations should be made based on the web entering from the left side of the roll and exiting at the right side.

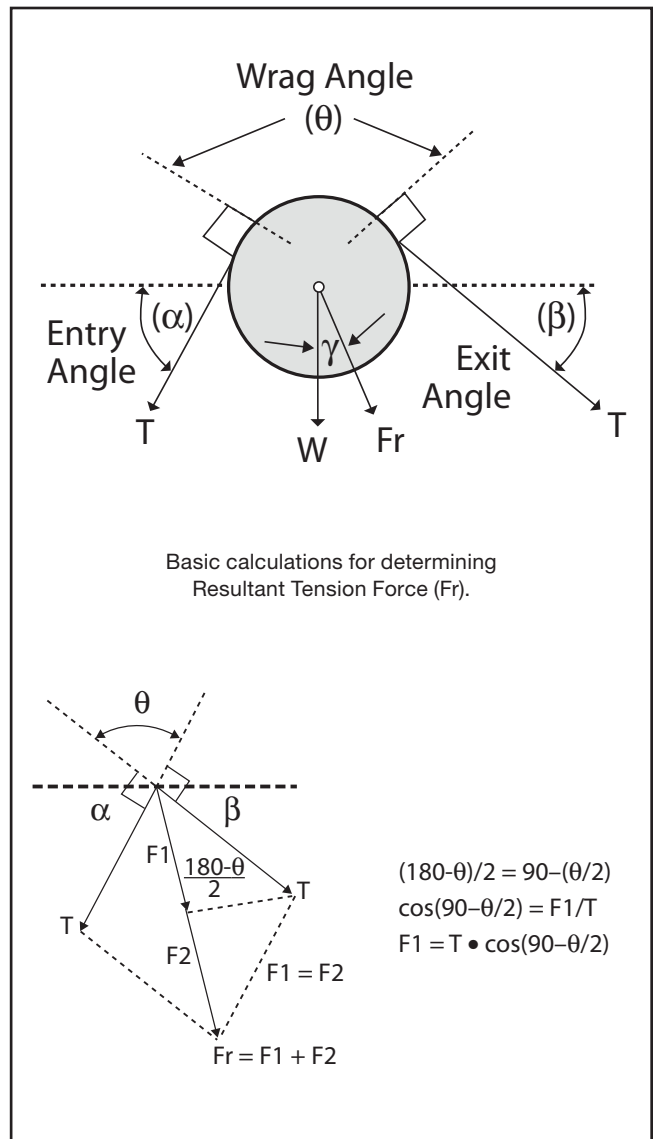

Web Tension Design

$$\theta = \alpha + \beta$$

Where:

θ = the web wrap angle (in degrees)

The resultant web tension force (F_r) is the vector sum of the entry and exit tensions (T).

$$F_r = T \cdot \cos(90-\theta/2) + T \cdot \cos(90-\theta/2)$$

$$\text{and } \cos(90-\theta/2) = \sin(\theta/2)$$

$$F_r = 2 \cdot T \cdot \sin(\theta/2)$$

Where:

F_r = Resultant web tension force (lb)

If you would like BLH to determine the proper transducer capacity selection, simply fill in the Web Tension Worksheet Information Sheet supplied with this Handbook and send or FAX to Vishay BLH Applications Engineering.

How About Roll Weights?

Ideally, F_r is the only force that should be measured. A negative value for F_r indicates that the force direction is upward from a horizontal plane; a positive value indicates that the force is downward. To take advantage of the directional characteristics of Vishay BLH transducers, install them in the direction of tension force along vector F_r . This angle is determined from the vertical as follows:

$$\gamma = (-\alpha + \beta)/2$$

Where:

γ = Angle of transducer rotation from the vertical for maximum sensitivity. Reference the following illustration for sign and directional conventions used in determining placement of γ .

Transducers must be sized to support both tension and roll weight. This combined force is calculated from the law of cosines as follows:

$$F_t = \sqrt{F_r^2 + W^2 - 2 \cdot F_r \cdot W \cdot \cos(180-\gamma)}$$

$$\text{and } \cos(180-\gamma) = -\cos(\gamma)$$

$$F_t = \sqrt{F_r^2 + W^2 + 2 \cdot F_r \cdot W \cdot \cos(\gamma)}$$

Note: It is important to follow sign conventions as shown below and to carry the correct sign for all calculated values through all equations.

Angle Conventions:

α, β always $\leq \pm 180^\circ$

γ always $\geq \pm 90^\circ$

To choose the right transducer capacity, calculate the maximum load supported (F_{max}) and select the next largest size unit. When the angle between the direction of the tension force (F_r) and the roll weight (W) is less than 90° , the maximum load is their vector sum (F_t) (F_{max} per roll end = $F_t/2$). At angles greater than 90° , either the roll weight (W) or the tension force (F_r) plus the component of roll weight acting in the direction of F_r (F_w) may present the highest load (F_{max} per roll end = $(F_r + F_w)/2$).

$$F_w = W \cdot \cos \gamma$$

Where:

F_w = Component of roll weight (W) acting along vector F_r . (lb)

$$F_{max} = F_t/2$$

$$F_{max} = W/2$$

$$F_{max} = (F_r + F_w)/2$$

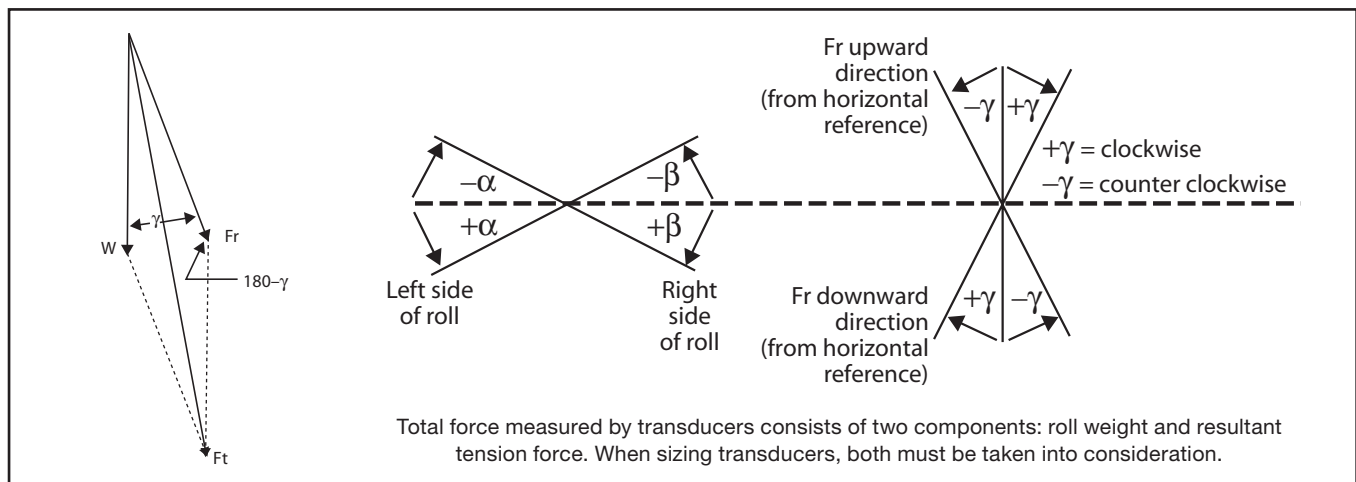

Web Tension Design

Where:

F_{max} = Force at each end of roll

Choose the largest absolute value of F_{max} and select the appropriate transducer capacity. T-MAC systems have a capacity of twice the value of an individual transducer capacity. Sizing calculations and selection criteria assume that the force is evenly distributed between each transducer. In an installation where this is not the case, consideration should be given to the maximum force supported by each transducer. Although short term operation of a transducer above its capacity but below the safe load (reference data sheets) will not damage the unit, continuous operation at greater than 120% of rated capacity may cause accelerated fatigue failure.

Note: In cases where a transducer will be mounted on a support surface that is not horizontal, consult Vishay BLH for appropriate transducer model and size selection. To request a computerized sizing calculation and transducer model selection for your application, complete the Web Tension Application Work Sheet and fax it to Vishay BLH Applications Engineering (781) 828-1451. Work and Specification Sheets may be obtained at www.vishay.com.

Chapter VI – Intrinsic Safety

This chapter provides abbreviated information concerning intrinsically safe installations. For a complete dossier on this subject, ask your local sales representative for a copy of TD-067, A Guide to SAFE Weighing in Hazardous Locations. Although the focus of this document is electronic weighing, all principals apply to web tension measurement as well.

What is the Basis of Intrinsic Safety?

Intrinsic Safety originates from the American National Standards Institute (ANSI), National Fire Protection Agency (NFPA), and National Electric Code (NEC). The stated purpose of the (NEC) code is ‘the practical safeguarding of persons and property from hazards arising from the use of electricity’. Articles 500 through 517 of the code cover the installation of electrical equipment in locations where fire or explosion hazards may exist due to flammable gases or vapors, flammable liquids, combustible dust, or ignitable fibers.

What Do the Different Classifications Mean?

The classification of hazardous areas is dependent upon the properties of various hazardous materials and the likelihood of their presence. The following table is an interpretation of the class locations.

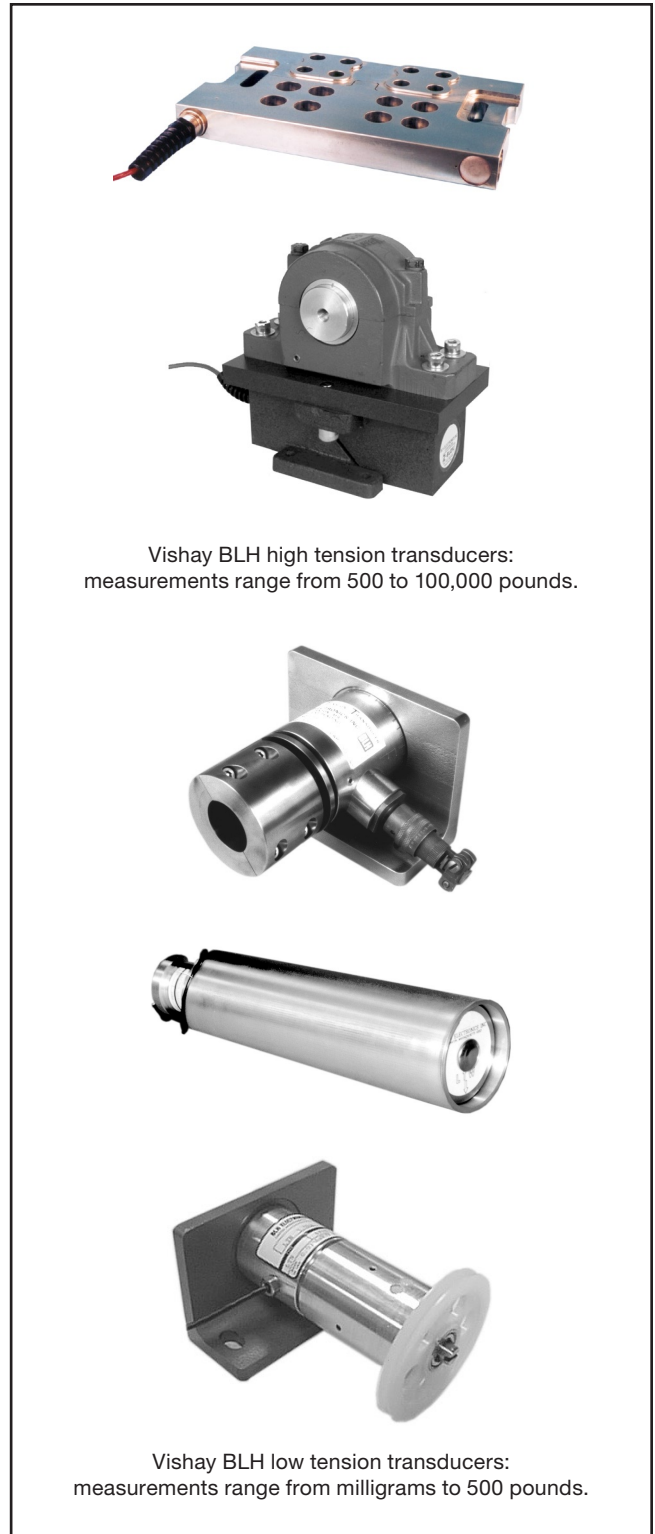

Vishay BLH high tension transducers:
measurements range from 500 to 100,000 pounds.

Vishay BLH low tension transducers:
measurements range from milligrams to 500 pounds.

Web Tension Design

Hazardous Location Classifications	
Class	Description
I	Vapor
II	Dust
III	Fiber
Division	Description
1	Always present
2	Present under fault condition
Group	Description
A	Acetylene
B	Hydrogen
C	Ethylene
D	Propane
E	Metal dust
F	Carbon dust
G	Grain dust

Will I Need A Special Enclosure?

Any instrumentation located in a Division 1 area must be either purged or housed in an explosion-proof enclosure.

In non-incendive Class I, Division 2 areas, however, different standards apply. Non-incendive equipment is incapable of releasing sufficient electrical or thermal energy to ignite flammable gases or vapors under ‘normal’ operating conditions. Equipment of this type can be used without special enclosures or other safeguards. In order for equipment to qualify as non-incendive, thermal energy from devices such as power supplies, resistors, etc., must be below that required to ignite the anticipated

hazard. In addition, the energy released at make and break contacts within the circuit must be below the minimum required energy needed to ignite the hazard. Nearly all Vishay BLH instruments carry FM (Factory Mutual) and CSA (Canadian Standards Association) non-incendive approvals.

Do I Need Intrinsic Safety Barriers?

If the transducers/tension modules are located in a Division 1 area, the answer is yes. Even if the instrumentation is located in a safe area, safety barriers are required to limit transducer voltage levels.

How Does Intrinsic Safety Work?

Intrinsic Safety is based on the principal of restricting electrical energy available in the hazardous area equipment circuits under both normal and fault operating conditions. Limiting energy below the minimum level required to ignite the material makes any sparking contacts or heat producing components incapable of being an ignition source. This type of protection is used in Division 1 Locations. Intrinsically safe equipment can be approved as a complete system (loop) or as individual components under the ‘entity’ concept. A loop approval will specify each component of a system and the interconnection methods etc., needed to gain and maintain an approval. The entity approval of a component of a system will allow for the interconnection of apparatus not specifically examined as a combination. The criteria for the interconnection is that specific entity parameters such as voltage, current, capacitance, and inductance are observed.

How Can I Tell if My Equipment is Safe to Use?

In many cases the NEC requires that the equipment used in

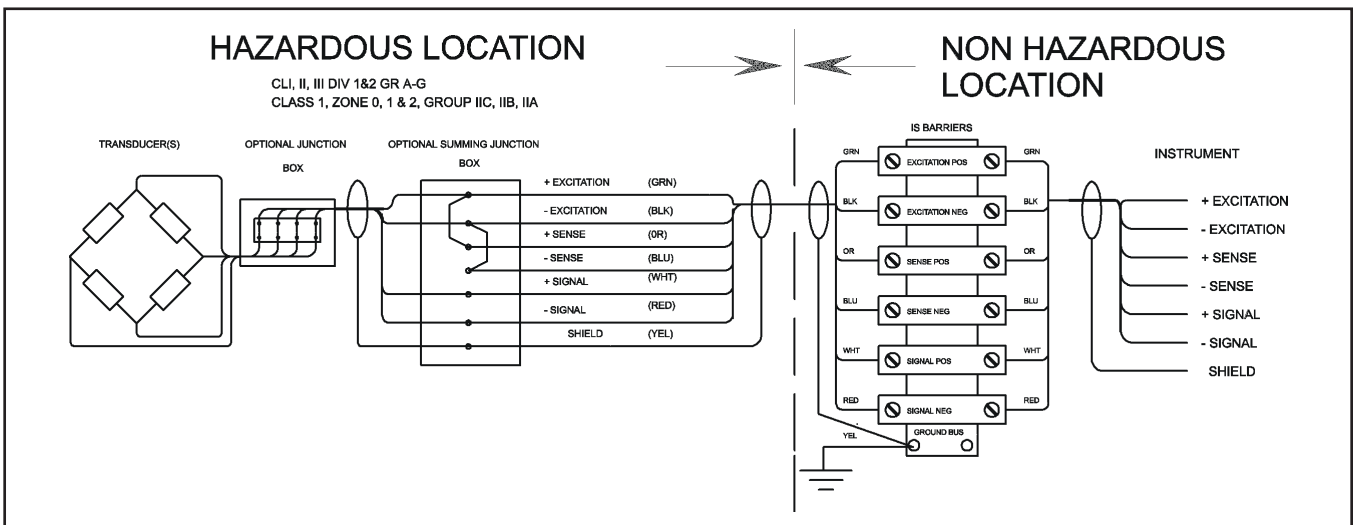



Web Tension Design

hazardous locations be 'approved' by the authority having jurisdiction. The 'authority' can be a local building code official, fire marshal, insurance company, plant safety committee, or any combination thereof. These authorities often require that equipment be evaluated by a third party organization to ensure conformance to recognized standards. In the U.S.A., the predominant third party test/

evaluation organizations are Factory Mutual Research (FM) and Underwriters Laboratories (UL). The standards applied to hazardous location equipment are developed and maintained by FM and UL and in some cases ISA and/or ANSI. Look for FM and (in Canada) CSA approvals on both transducers and instrumentation. These approvals should be accepted by State and Local Authorities.



Web Tension Design

Chapter VII – Glossary

Adapter Plate:	Mild steel or stainless steel plates which mount on either side of a load cell to accept pillow block bearings and frame work configurations on new and existing machines.
Angle of Inclination:	Angle between the vertical reference plane and the resultant force (Fr) of a given tension zone.
Converting:	Changing web material from one form to another. This process includes calendaring, coating, die cutting, embossing, laminating, printing, punching, sheeting, slitting, treating, winding and unwinding.
Core:	The roll upon which web material is wound.
Core Shaft:	A mandrel upon which rolls are wound
Critical Speed:	A condition where the roller rpm matches its beam bending natural frequency and, thus, results in large amplitude vibrations.
Damping:	The resistance to motion which dissipates vibratory energy.
Dancer:	A pivoting roller sensor used for feedback control of web tension.
Dead Load:	A non-varying or static load which constantly factors into force measurement (i.e. roll weight).
Deflection:	The change in length along the Primary Axis of the transducer between no-load and rated load conditions.
Drive Roller:	A roller which is driven or braked by a device such as an electric motor, belt, brake, or clutch.
Entry Angle (α):	Angle between a reference plane which is usually horizontal and the entering web tangent point of contact on a roller.
Excitation, Electrical:	The voltage or current applied to the input terminals of the load cell.
Exit Angle (β):	Angle between a reference plane which is usually horizontal and the exiting web tangent point of contact on a roller.
Frequency Response:	The range of frequencies over which the transducer output will follow the sinusoidally varying mechanical input within specified limits. Normally expressed as "within... percent from... to... Hzfl."
Idler Roller:	A roller which is driven by the web rather than by an electric motor, belt or other external means.
Intermediate Zone:	An independent tension zone in the web path typically created between two driven nip points.
Live Load:	A dynamic load of variable force (tension) acting upon a structure in addition to its own weight (dead load).
Load Cell:	A sensing device (strain gage based) which produces an output signal proportional to the applied weight or force. The term is often used interchangeably with tension transducer.
Natural Frequency:	The frequency of free oscillations under no-load conditions.
Nip:	To load two parallel rollers together. A nip between two rollers is used in calendaring, laminating, and printing. A nip between a wound roll and a roller (or drum) is one of the three TNT's of winding which control how hard the rolls are wound.
Output:	The signal (voltage, current, pressure, etc.) produced by the tension transducer.
Pillow Block:	An integral bearing/housing style that mounts to a tension module adapter plate. Typical installation requires 2 or 4 bolts.



Web Tension Design

PLI:	Pounds per linear inch. Abbreviation for lineal force per unit width denoted as lb/in. Used for tension, nip, and torque.
Primary Axis:	The axis along which the tension transducer is designed to be loaded; normally the geometric center line.
Resolution:	The smallest change in mechanical input which produces a detectable change in the output signal.
Resonance:	A condition of vibration amplification when running at a speed corresponding to a structural natural frequency.
Resultant Force (Fr):	Resultant web tension force (Fr) is the vectorial sum of the tension forces within a given wrap angle and is typically measured in lb, kg, N, and g.
Rewind Zone:	A tension zone, typically on converting machinery, created between a driven nip roll or other tensioning point and the driven core onto which the web is wound.
Roll:	A web in wound roll form. This term is also used for rollers.
Roller:	A rotating cylindrical shaft used for web transport. Also called drums and rolls.
Runability:	A measure of the mean distance between web breaks on a winder or other converting machine.
Safe Range:	The extremes of temperature within which a tension transducer will operate without permanent adverse change to any of its performance characteristics.
Strain Gage:	An electrical resistance sensing device which measures changes in strain or stress upon the sensing element (bar of steel, spring, beam, etc.) the gage is bonded to.
Segmented Roller:	A series of two or more coaxially located rollers. By segmenting rollers, smaller diameters can be used to avoid the requirement of a drive.
Sensitivity:	The ratio of the change in output to the change in mechanical input.
Setpoint:	A control setting, (dial position, etc.) for a single process control variable.
Substrate:	The material that a web is made of.
Tension Transducer:	A strain gage based sensor designed to measure precise tension values in web handling machinery. The term is often used interchangeably with load cell.
Tension Zone:	A length of machine in which the web is under nominally the same tension, usually between driven rollers.
Time Constant:	The time to effect a change that is 67% of the way from an initial state to a final state. For example, the time constant of a web in a draw zone is span length divided by web velocity.
TNT:	Short for Tension, Nip, and Torque controls of winding tension.
Total System Force:	(Ft) Vectorial sum of the roll weight and the resultant web tension force.
Unwind Zone:	A tension zone created between a driven roll or driven nip and the core from which a roll is unwound. Tension is often created by torque applied to the unwind shaft by a pneumatic brake.
Web:	A long, thin, flexible structure. Common web materials include paper, film, foil, nonwovens and textiles. Typical widths: narrow, up to 7 inches; wide, 7 to 400 inches.
Wrap Angle (θ):	The angle between the entry and exit tangent of a web on a roller, or equivalently, the angle the web deflects as it goes over the roller. High wrap angles help insure web/roller traction.



Web Tension Design

NOTICE Specifications of the products displayed herein are subject to change without notice. Vishay Intertechnology, Inc., or anyone on its behalf, assumes no responsibility or liability for any errors or inaccuracies. Information contained herein is intended to provide a product description only. No license, express or implied, by estoppel or otherwise, to any intellectual property rights is granted by this document. Except as provided in Vishay's terms and conditions of sale for such products, Vishay assumes no liability whatsoever, and disclaims any express or implied warranty, relating to sale and/or use of Vishay products including liability or warranties relating to fitness for a particular purpose, merchantability, or infringement of any patent, copyright, or other intellectual property right. The products shown herein are not designed for use in medical, life-saving, or life-sustaining applications. Customers using or selling these products for use in such applications do so at their own risk and agree to fully indemnify Vishay for any damages resulting from such improper use or sale.

WORLDWIDE SALES AND TECHNICAL SUPPORT

THE AMERICAS

VISHAY SYSTEMS AMERICAS

3 EDGEWATER DRIVE
 NORWOOD, MA 02062
 USA
 PH: +1-781-298-2200
 FAX: +1-781-762-3988
 E-MAIL: VTS.US@VISHAYMG.COM

VISHAY SYSTEMS CANADA

12 STEINWAY BLVD, UNIT 1
 TORONTO, ONTARIO M9W 6M5
 CANADA
 PH: +1-800-567-6098 (TOLL FREE)
 +1-416-251-2554
 FAX: +1-416-251-2690
 E-MAIL: VT.CAN@VISHAYMG.COM

ASIA

VISHAY SYSTEMS TAIWAN*

15 FL, NO. 86, SEC.1 SHINTAI 5TH RD.
 SHIJR CITY, TAIPEI, 221
 TAIWAN, R. O. C.
 PH: +886-2-2696-0168
 FAX: +886-2-2696-4965
 E-MAIL: VT.ROC@VISHAYMG.COM
 *ASIA EXCEPT CHINA

VISHAY SYSTEMS CHINA

NO. 5 BINGUAN NAN DAO YOUYI RD.
 HEXI DISTRICT, TIANJIN CHINA
 CODE 300061
 PH: +86-22-2835-3503
 FAX: +86-22-2835-7261
 E-MAIL: VT.PRC@VISHAYMG.COM

EUROPE

VISHAY MEASUREMENTS GROUP UK

STROUDLEY ROAD
 BASINGSTOKE
 HAMPSHIRE RG24 8FW
 UNITED KINGDOM
 PH: +44-125-685-7490
 FAX: +44-125-634-6844E-MAIL:
 VT.UK@VISHAYMG.COM

VISHAY MEASUREMENTS GROUP

GERMANY
 TATSCHENWEG 1
 74078 HEILBRONN
 GERMANY
 PH: +49-7131-3901-260
 FAX: +49-7131-3901-2666
 E-MAIL: VT.DE@VISHAYMG.COM

VISHAY MEASUREMENTS GROUP

FRANCE
 16 RUE FRANCIS VOVELLE
 28000 CHARTRES
 FRANCE
 PH: +33-2-37-33-31-25
 FAX: +33-2-37-33-31-29
 E-MAIL: VT.FR@VISHAYMG.COM

VISHAY SYSTEMS SWEDEN

P.O. BOX 423
 SE-691 27 KARLSKOGA
 SWEDEN
 PH: +46-586-63000
 FAX: +46-586-63099
 E-MAIL: VT.SE@VISHAYMG.COM

VISHAY SYSTEMS NORWAY

BROBEKKVEIEN 80
 0582 OSLO
 NORWAY
 PH: +47-22-88-40-90
 FAX: +47-22-88-40-99
 E-MAIL: VT.SE@VISHAYMG.COM

VISHAY MEASUREMENTS GROUP ISRAEL

8A HAZORAN STREET
 P.O. BOX 8381, NEW INDUSTRIAL ZONE
 NETANYA 42506
 ISRAEL
 PH: +972-9-863-8888
 FAX: +972-9-863-8800
 E-MAIL: VT.IL@VISHAYMG.COM

One of the World's Largest

Manufacturers

of Discrete Semiconductors and Passive Components